

Safely through winter

Vessels up to -20°C operating temperatures

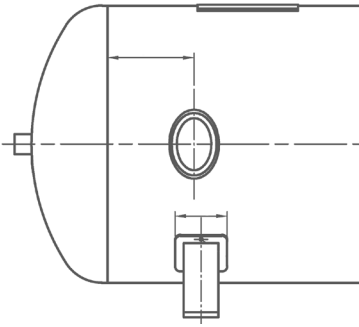
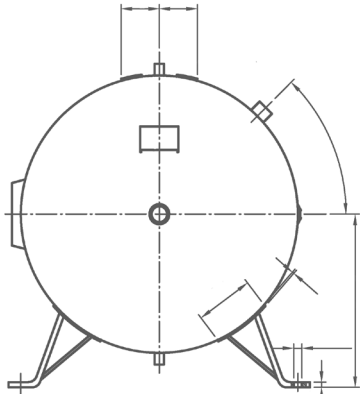

Starting today the minimum operating temperature for our vessels above a volume of 150 Liter and 11 & 16 bar is no more -10°C , but -20°C !

Therefore we meet the specifications of the AD200 code, the pressure vessel guidelines and the industrial safety regulation.

Your advantages:

- » our vessels can be operated safely during winter times
- » our standard vessel 150 - 3.000 Liter (11 & 16 bar) are manufactured for -20°C / $+50^{\circ}\text{C}$
- » this provides you with new ranges of applications and perhaps new selling advantages
- » the improvements of our vessels do not cause additional costs for you

Extract from the AD2000 code, B0 paragraph 5.3

... When determine the wall temperature, the ambient temperature and operating temperature have to be considered...

Extract from the DGRL97/23/EG, enclosure I; 2.2.3 b

... During the configuration all possible temperature- and pressure combinations must be considered, which could occur while using reasonable judgement when operating the device...



Your application, our pressure vessels -
Further developed - continuously improved!

Contact:

Sven Watzek
 +49 2743 9330 28
 s.watzek@mabe.de

Thomas Ermert
 +49 2743 9330 21
 t.ermert@mabe.de

www.mabe.de

