

OAB 51 - handhole lock 100/150
tested components

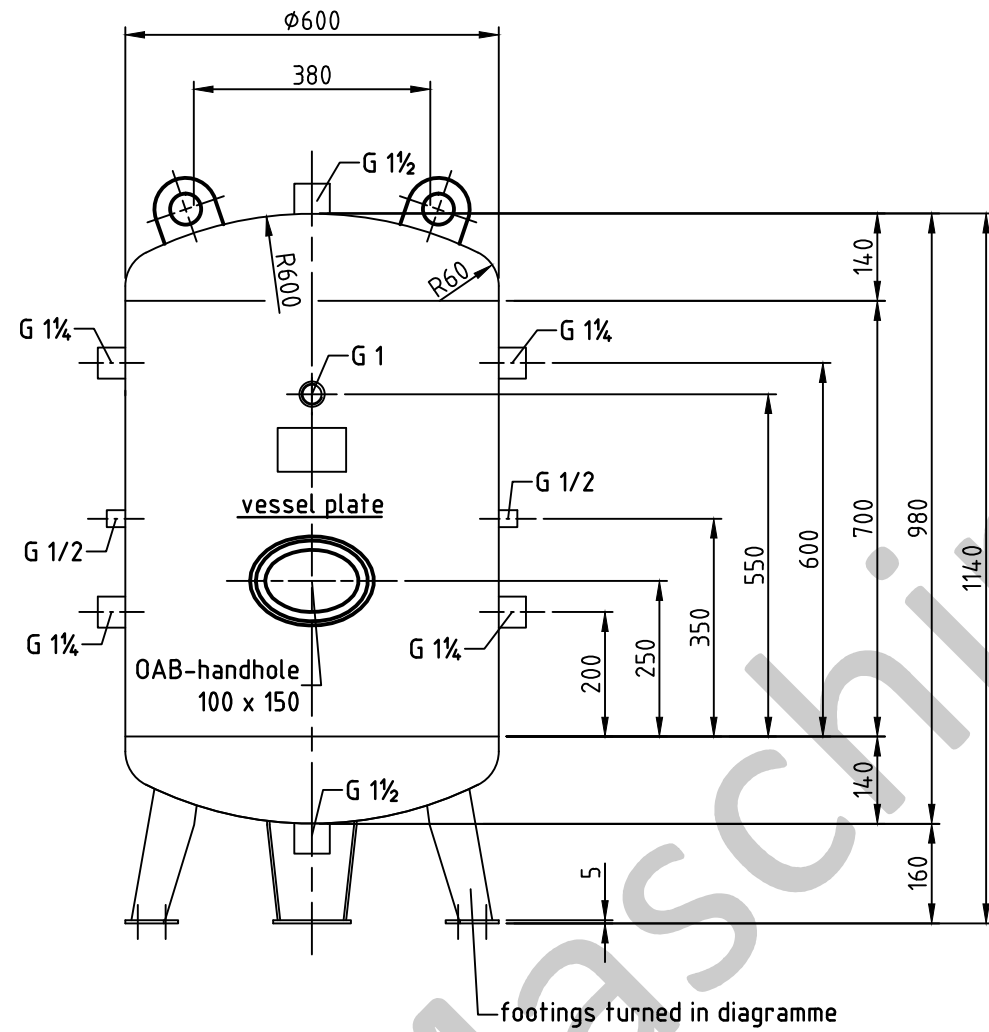

socket welding
drain and plug socket
inside flush

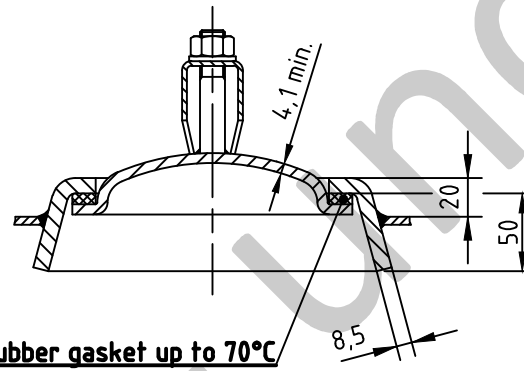
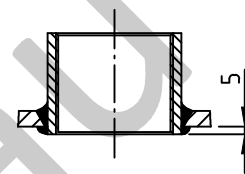

carrier eye

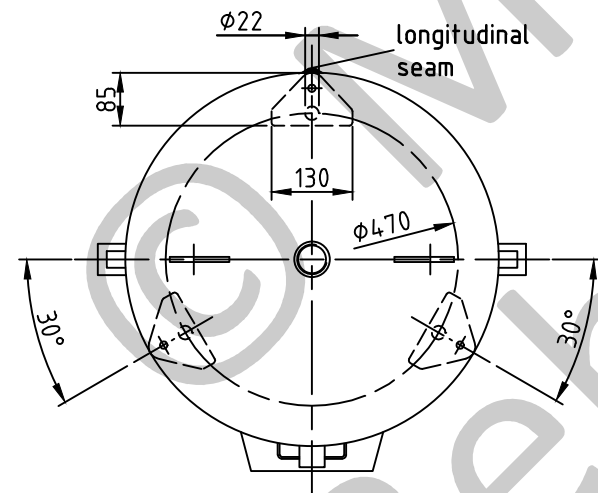
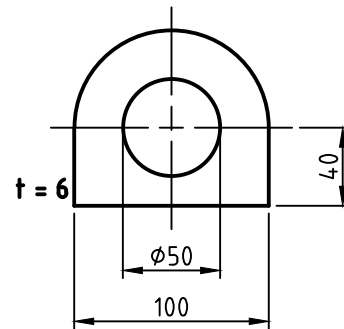

SEAMS (unless otherwise indicated on drawing):

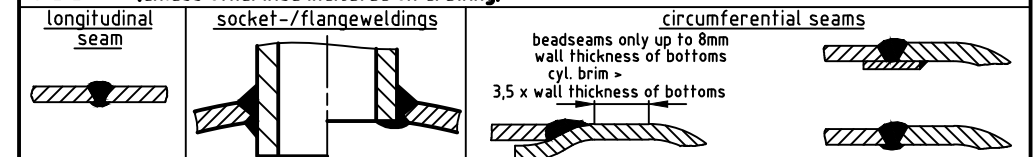

pressure variation :
pressure swing 0-11 bar max. operations 1.000
infinite operation of pressure swing within 20% of 11 bar
operational characteristics / calculation characteristics :
volume V (litre) : 250
max. working pressure PS (bar) : 11
test pressure PT (bar) : 15,73
min. working temp. TS (°C) : -20
max. working temp. TS (°C) : 50
fluid : compressed air / nitrogen (fluid group 2)
location : inside and outside building possible

coating :		
inside : raw	or:	inside : hot dip galvanized
outside : primed (if customer wishes lacquered)		outside : hot dip galvanized

manufacturing and testing
acc. to PED 2014 / 68 / EU - AD 2000

conformity benchmark :	
fluid group : 2	categorie : III
diagram : 2	module : H1

scale :	1:12.5
our no. :	-
order no. :	-
used for :	M+B Standardvessel
weight :	ca.110 kg
sheet :	1
of sheet :	1
date of plot :	10.06.2015
file :	ENG-010671

Maschinen- und Behälterbau GmbH

date	name
compl. 10.06.2015	CW
appr. 10.06.2015	Nota 2

follow protection mark acc. to DIN 34

Betzdorfer Str. 170
57567 Daaden
Tel. 02743/9330-12
Fax 02743/3685
Internet: www.mabe.de
E-Mail: cad@mabe.de

description :	
pressure vessel upright 250 l 11 bar	
drawing no. :	revision : A
MB 030605-1.250/E	
drawing no. of design inspection :	date of revision : 10.06.2015
MB 030603-1	revision only on CAD