

OAB 51 - manhole lock 320/420
 tested components

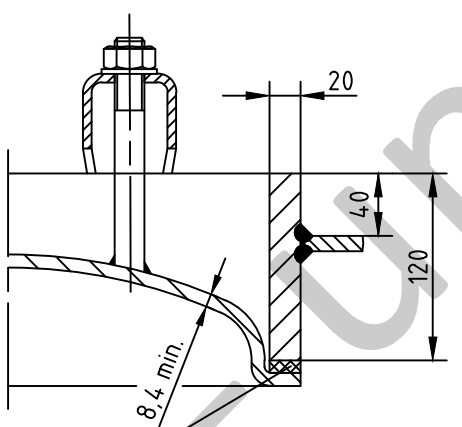

1a rubber gasket up to 70°C

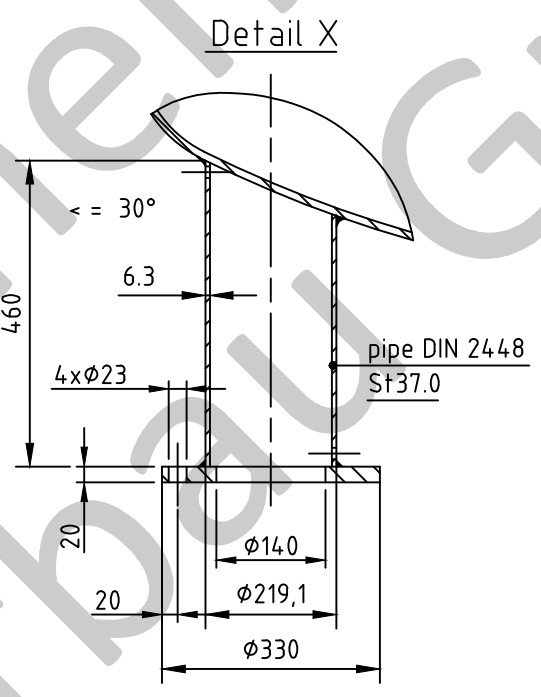

socket welding
 drain and plug socket
 inside flush

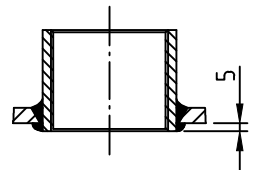

SEAMS (unless otherwise indicated on drawing):		
longitudinal seam	socket-/flangeweldings	circumferential seams
		beadseams only up to 8mm wall thickness of bottoms cyl. brim > 3,5 x wall thickness of bottoms
pressure variation :		
pressure swing 0-16 bar max. operations 1.000		
infinite operation of pressure swing within 20% of 16 bar		
operational characteristics / calculation characteristics :		
volume V (litre)	: 9000	
max. working pressure PS (bar)	: 16	
test pressure PT (bar)	: 22,88	
min. working temp. TS (°C)	: -10	
max. working temp. TS (°C)	: 50	
fluid	: compressed air / nitrogen (fluid group 2)	
location	: inside and outside building possible	
coating :		
inside : hot dip galvanized		
outside : hot dip galvanized		
manufacturing and testing		
acc. to PED 2014 / 68 / EU - AD 2000		
conformity benchmark :		
fluid group : 2	category : IV	
diagram : 2	module : H1	

scale :	1:25
our no. :	-
order no. :	-
used for :	M+B Standardvessel
weight :	ca.2320 kg
sheet :	1
of sheet :	1
date of plot :	22.06.2015
file :	ENG-010766

Maschinen- und Behälterbau GmbH

date	name
compl. 22.06.2015	CW
appr. 22.06.2015	Nota 2

follow protection mark acc. to DIN 34

Betzdorfer Str. 170
 57567 Daaden
 Tel. 02743/9330-12
 Fax 02743/3685
 Internet: www.mabe.de
 E-Mail: cad@mabe.de

description :	
pressure vessel upright 9000 l 16 bar	
drawing no. :	revision : A
MB 020103-2.9000V/E	
drawing no. of design inspection :	date of revision : 22.06.2015
MB 020103-2	revision only on CAD