

OAB 51 - handhole lock 100/150 tested components

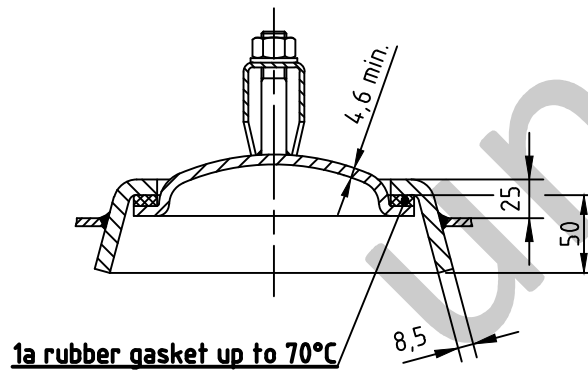

socket welding
drain and plug socket
inside flush

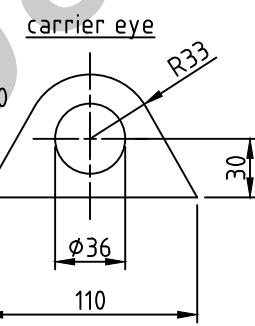
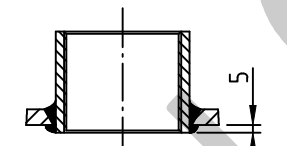

Detail X

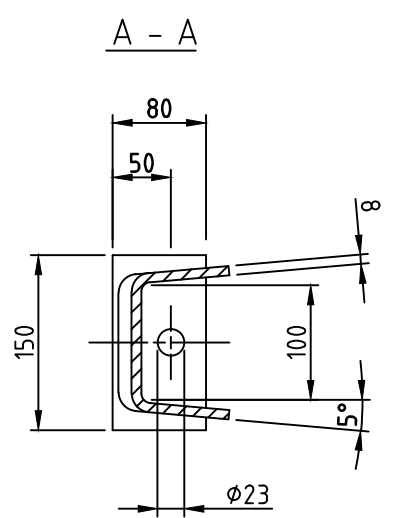
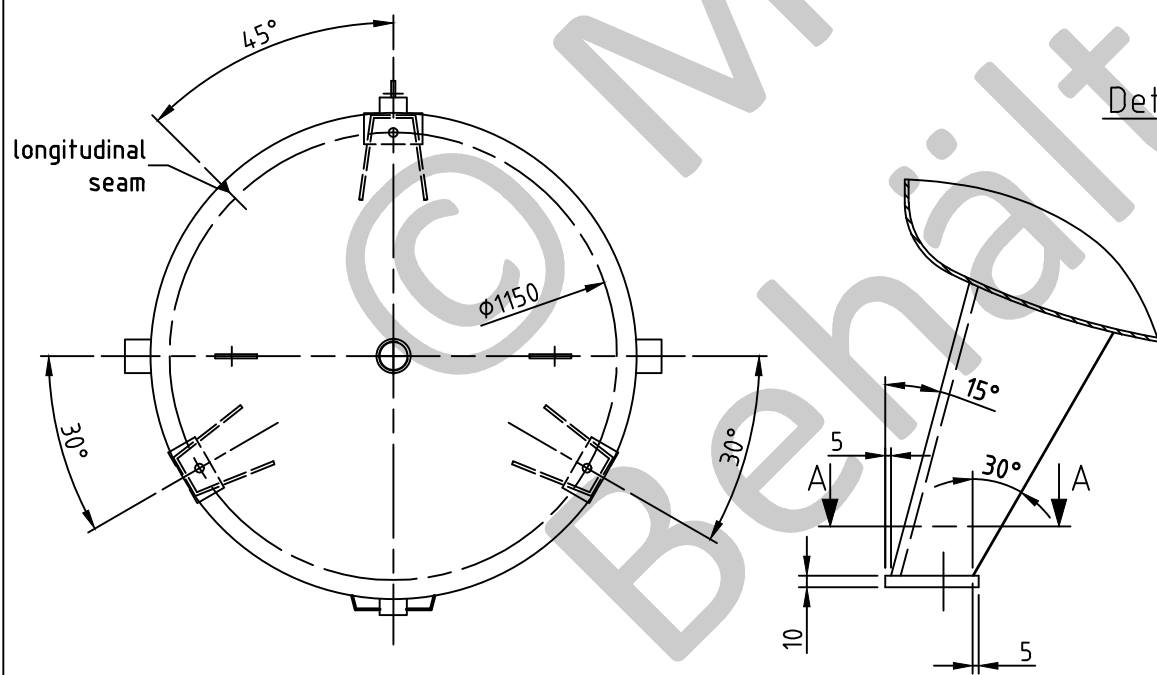

SEAMS (unless otherwise indicated on drawing):		
longitudinal seam	socket-/flangeweldings	circumferential seams
		beadseams only up to 8mm wall thickness of bottoms cyl. brim > 3,5 x wall thickness of bottoms
pressure variation :		
pressure swing 0-16 bar max. operations 1.000		
infinite operation of pressure swing within 20% of 16 bar		
operational characteristics / calculation characteristics :		
volume V (litre)	: 3000	
max. working pressure PS (bar)	: 16	
test pressure PT (bar)	: 22,88	
min. working temp. TS (°C)	: -20	
max. working temp. TS (°C)	: 50	
fluid	: compressed air / nitrogen (fluid group 2)	
location	: inside and outside building possible	
coating :		
inside : hot dip galvanized		
outside : hot dip galvanized		
manufacturing and testing		
acc. to PED 2014 / 68 / EU - AD 2000		
conformity benchmark :		
fluid group : 2	category : IV	
diagram : 2	module : H1	

scale :	1:20
our no. :	-
order no. :	-
used for :	M+B Standardvessel
weight :	ca. 850 kg
sheet :	1
of sheet :	1
date of plot :	17.06.2015
file :	ENG-010746

Maschinen- und Behälterbau GmbH

date	name
compl. 17.06.2015	CW
appr. 17.06.2015	Nota 2

follow protection mark acc. to DIN 34

Betzdorfer Str. 170
57567 Daaden
Tel. 02743/9330-12
Fax 02743/3685
Internet: www.mabe.de
E-Mail: cad@mabe.de

description :	
pressure vessel upright 3000 l 16 bar	
drawing no. :	revision : A
MB 020103-2.3000V/E	
drawing no. of design inspection :	date of revision : 17.06.2015
MB 020103-2	revision only on CAD