

OAB 51 - manhole lock 320/420
 tested components

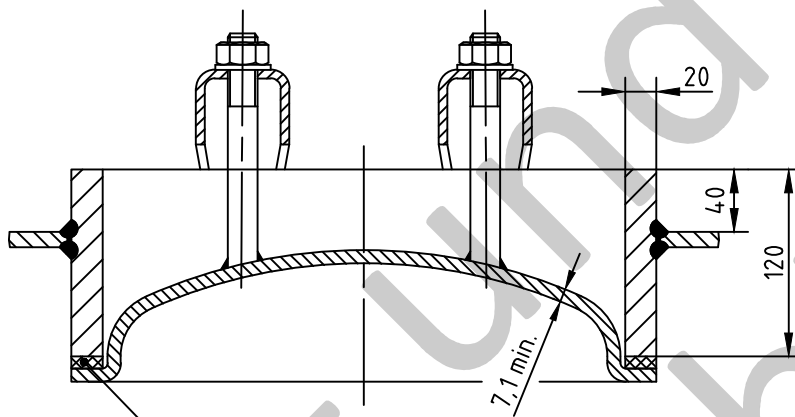

1a rubber gasket up to 70°C

socket welding
 drain and plug socket
 inside flush

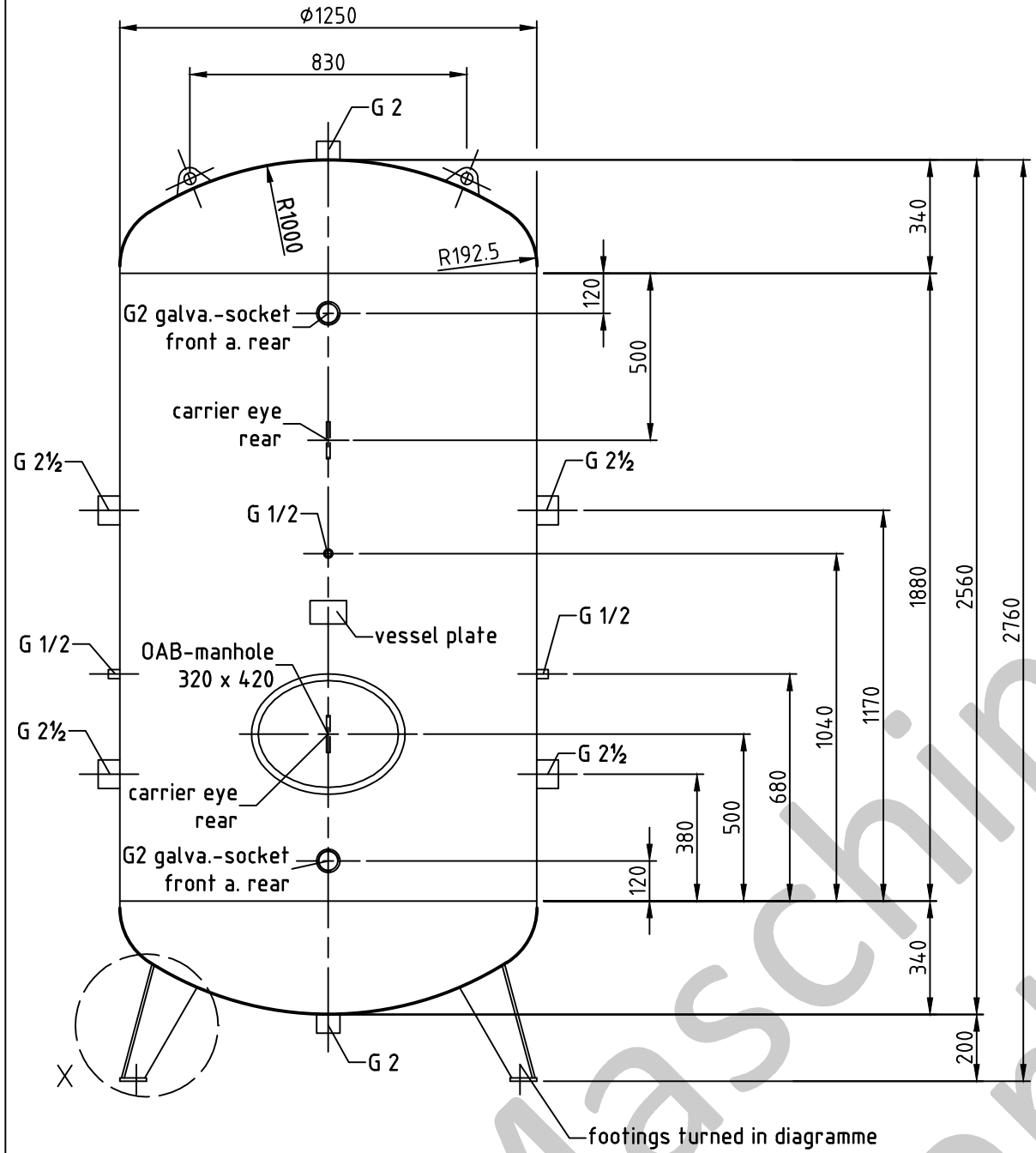
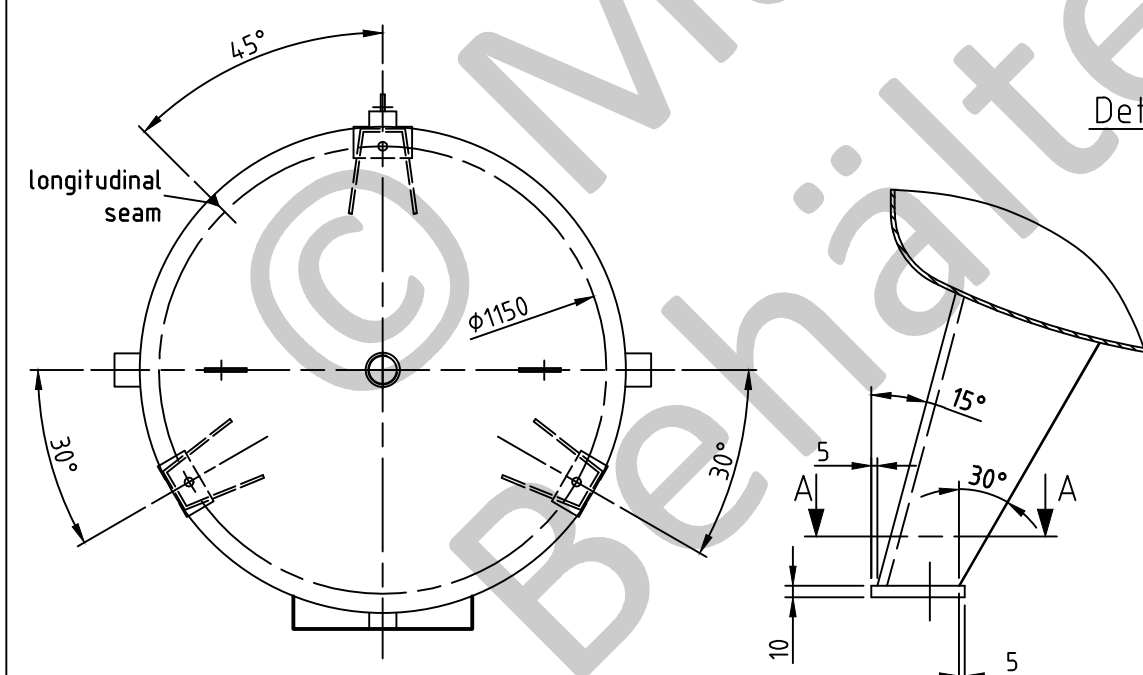
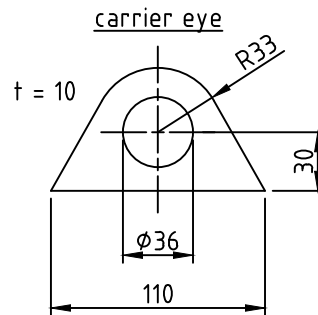
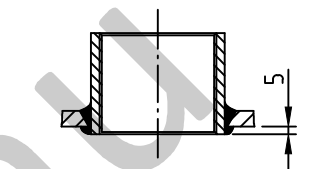

Detail X

A - A

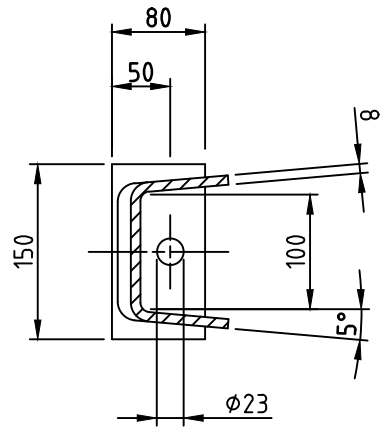

SEAMS (unless otherwise indicated on drawing):		
longitudinal seam	socket-/flangeweldings	circumferential seams
		beadseams only up to 8mm wall thickness of bottoms cyl. brim > 3,5 x wall thickness of bottoms
pressure variation :		
pressure swing 0-11 bar max. operations 1.000		
infinite operation of pressure swing within 20% of 11 bar		
operational characteristics / calculation characteristics :		
volume V (litre)	:	3000
max. working pressure PS (bar)	:	11
test pressure PT (bar)	:	15,73
min. working temp. TS (°C)	:	-20
max. working temp. TS (°C)	:	50
fluid	:	compressed air / nitrogen (fluid group 2)
location	:	inside and outside building possible
coating :		
inside : hot dip galvanized		
outside : hot dip galvanized		
manufacturing and testing		
acc. to PED 2014 / 68 / EU - AD 2000		
conformity benchmark :		
fluid group	:	2
diagram	:	2
categorie	:	IV
module	:	H1

scale :	1:20
our no. :	-
order no. :	-
used for :	M+B Standardvessel
weight :	ca. 660 kg
sheet :	1
of sheet :	1
date of plot :	15.06.2015
file :	ENG-010694

Maschinen- und Behälterbau GmbH

date	name
compl. 15.06.2015	CW
appr. 15.06.2015	Nota 2

follow protection mark acc. to DIN 34

Betzdorfer Str. 170
 57567 Daaden
 Tel. 02743/9330-12
 Fax 02743/3685
 Internet: www.mabe.de
 E-Mail: cad@mabe.de

description :	
pressure vessel upright 3000 l 11 bar	
drawing no. :	revision : A
MB 020103-1.3000V/M/E	
drawing no. of design inspection :	date of revision : 15.06.2015
MB 020103-1	revision only on CAD