

OAB 51 - manhole lock 320/420  
tested components

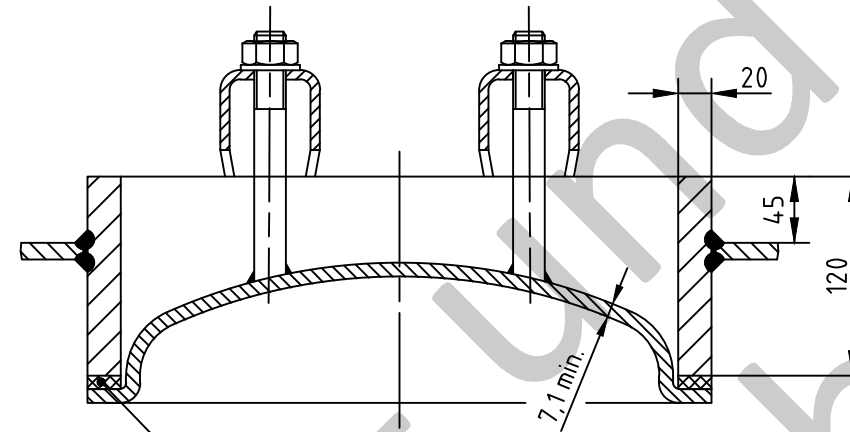

1a rubber gasket up to 70°C

socket welding  
drain and plug socket  
inside flush

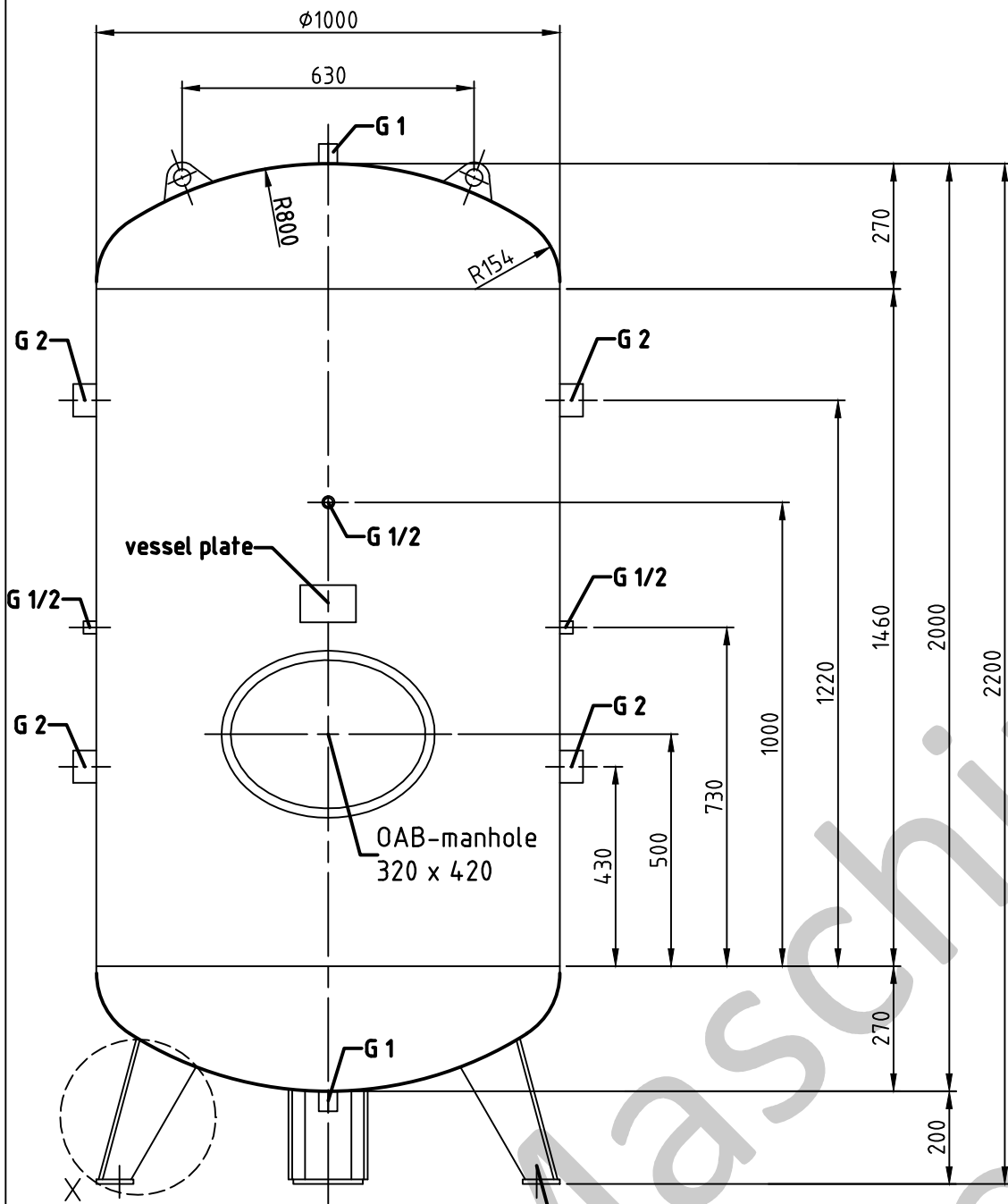
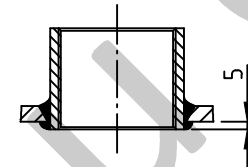

carrier eye

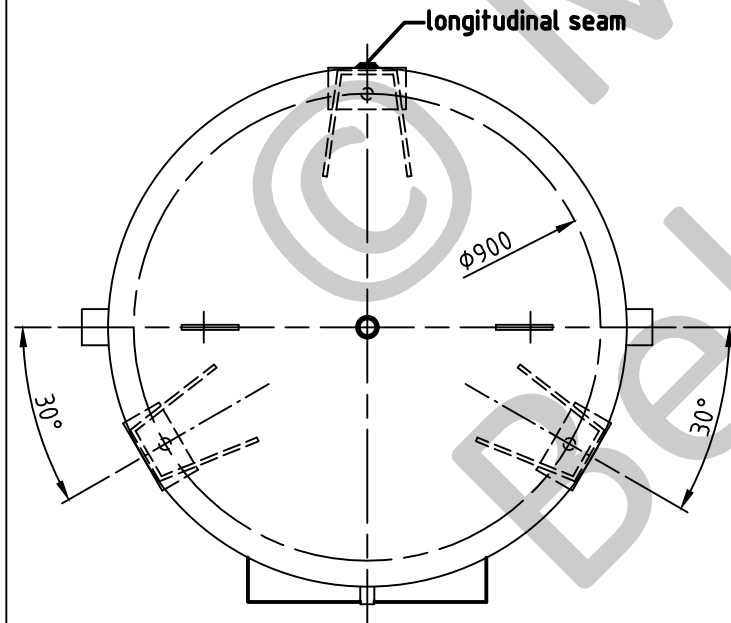
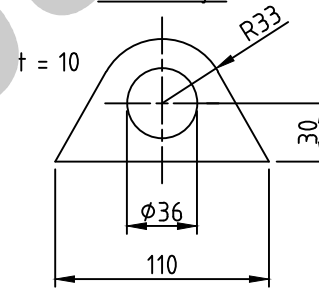

longitudinal seam

footings turned in diagramme

Detail X

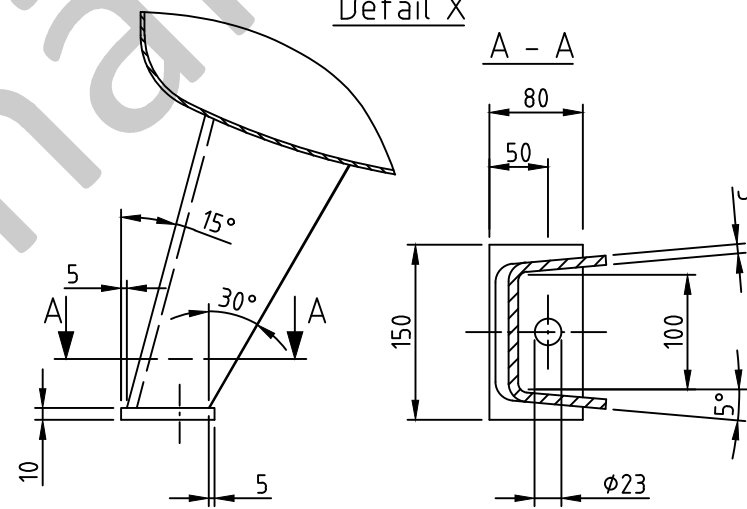

SEAMS (unless otherwise indicated on drawing):

longitudinal seam	socket-/flangeweldings	circumferential seams
		beadseams only up to 8mm wall thickness of bottoms cyl. brim > 3,5 x wall thickness of bottoms

pressure variation :

pressure swing 0-11 bar max. operations 1.000

infinite operation of pressure swing within 20% of 11 bar

operational characteristics / calculation characteristics :

volume V (litre)	: 1500
max. working pressure PS (bar)	: 11
test pressure PT (bar)	: 15,73
min. working temp. TS (°C)	: -20
max. working temp. TS (°C)	: 50
fluid	: compressed air / nitrogen (fluid group 2)
location	: inside and outside building possible

coating :

inside : raw

outside : primed (if customer wishes lacquered)

manufacturing and testing

acc. to PED 2014 / 68 / EU - AD 2000

conformity benchmark :

fluid group : 2  
diagram : 2

categorie : IV  
module : H1

scale :	1:15
our no. :	-
order no. :	-
used for :	M+B Standardvessel
weight :	ca.410 kg
sheet :	1
of sheet :	1
date of plot :	10.06.2015
file :	ENG-010683

Maschinen- und Behälterbau GmbH

date	name
compl. 10.06.2015	CW
appr. 10.06.2015	Nota 2

follow protection mark acc. to DIN 34

Betzdorfer Str. 170  
57567 Daaden  
Tel. 02743/9330-12  
Fax 02743/3685  
Internet: www.mabe.de  
E-Mail: cad@mabe.de

description :

pressure vessel upright  
1500 l 11 bar

drawing no. :  
MB 020103-1.1500G/M/E

drawing no. of design inspection :

MB 020103-1

revision :  
A

date of revision :  
10.06.2015

revision only  
on CAD