

view A

socket welding
 drain and plug socket
 inside flush

OAB 51 - manhole lock 320/420
 tested components

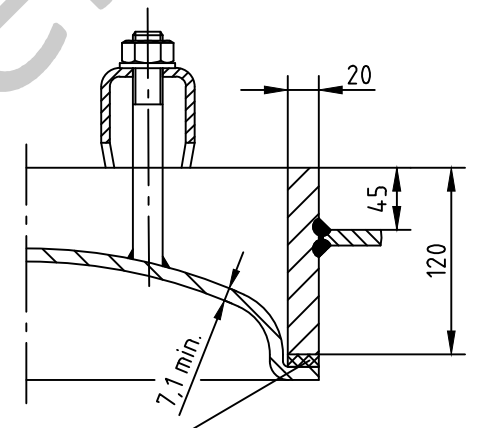
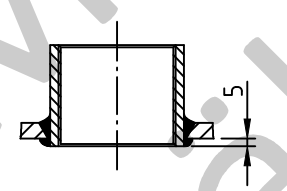

1a rubber gasket up to 70°C

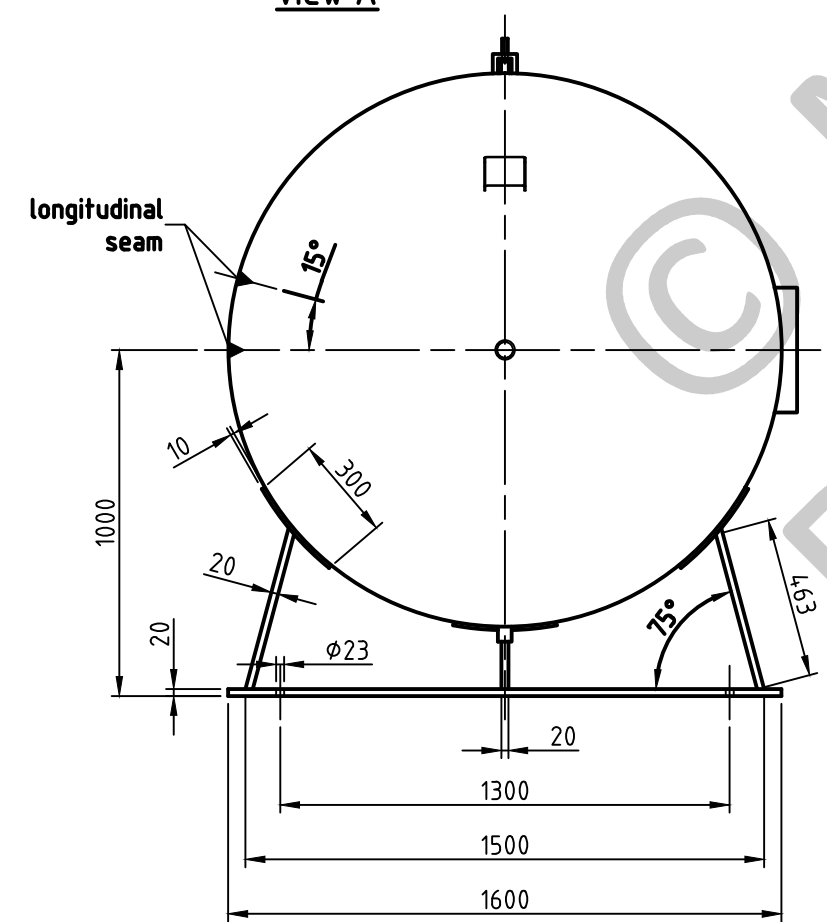
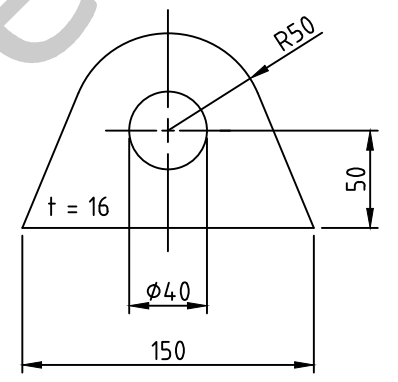

seams		
longitudinal seam (unless otherwise indicated on drawing):	socket-/flangeweldings	circumferential seams beadseams only up to 8mm wall thickness of bottoms cyl. brim > 3,5 x wall thickness of bottoms

pressure variation :	
pressure swing 0-11 bar max. operations 1.000	
infinite operation of pressure swing within 20% of 11 bar	
operational characteristics / calculation characteristics :	
volume V (litre)	: 9000
max. working pressure PS (bar)	: 11
test pressure PT (bar)	: 15,73
min. working temp. TS (°C)	: -10
max. working temp. TS (°C)	: 50
fluid	: compressed air/nitrogen (fluid group 2)
location	: inside and outside building possible
coating :	
inside : raw	
outside : primed (if customer wishes lacquered)	
manufacturing and testing	
acc. to PED 2014 / 68 / EU - AD 2000	
conformity benchmark :	
fluid group : 2	categorie : IV
diagram : 2	module : H1

scale :	1:22.5
our no. :	-
order no. :	-
used for :	M+B Standardvessel
weight :	ca.1600 kg
sheet :	1
of sheet :	1
date of plot :	24.06.2015
file :	ENG-010811

Maschinen- und Behälterbau GmbH

date	name
compl. 24.06.2015	CW
appr. 24.06.2015	Nota 2

follow protection mark acc. to DIN 34

Betzdorfer Str. 170
 57567 Daaden
 Tel. 02743/9330-12
 Fax 02743/3685
 Internet: www.mabe.de
 E-Mail: cad@mabe.de

description :	
pressure vessel horizontal 9000 l 11 bar	
drawing no. :	revision : A
MB 020102-1.9000G/E	
drawing no. of design inspection :	date of revision : 24.06.2015
MB 020102-1	revision only on CAD