

view A

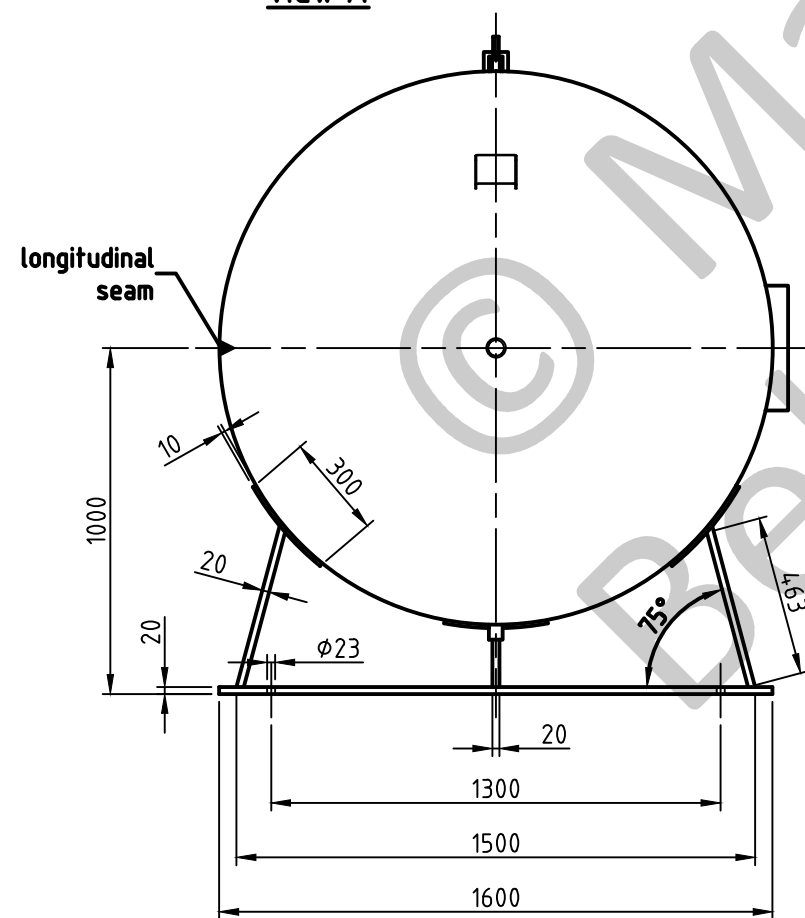

socket welding
drain and plug socket
inside flush

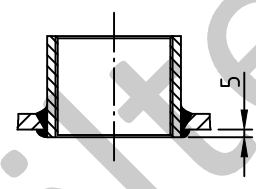

OAB 51 - manhole lock 320/420
tested components

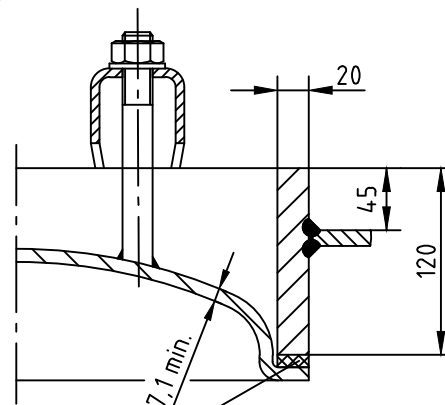

1a rubber gasket up to 70°C

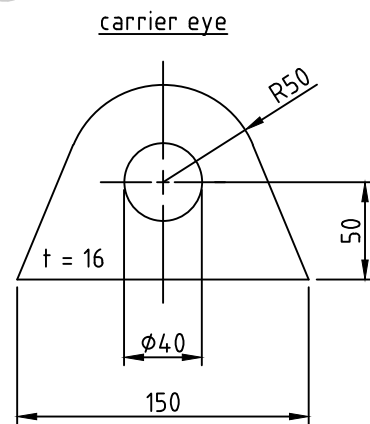

SEAMS (unless otherwise indicated on drawing):

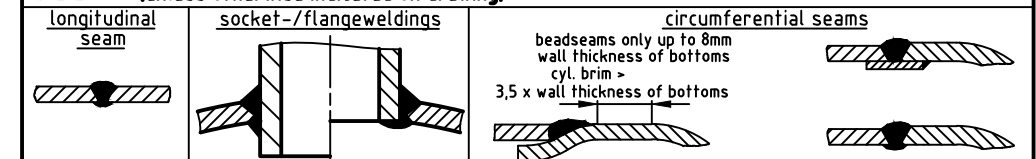

pressure variation :	
pressure swing 0-11 bar max. operations 1.000	
infinite operation of pressure swing within 20% of 11 bar	
operational characteristics / calculation characteristics :	
volume V (litre)	: 7000
max. working pressure PS (bar)	: 11
test pressure PT (bar)	: 15,73
min. working temp. TS (°C)	: -10
max. working temp. TS (°C)	: 50
fluid	: compressed air (fluid group 2)
location	: inside and outside building possible

coating :	
inside :	raw
outside :	primed (if customer wishes lacquered)

manufacturing and testing	
acc. to PED 2014 / 68 / EU - AD 2000	

conformity benchmark :	
fluid group : 2	categorie : IV
diagram : 2	module : H1

scale :	1:22.5
our no. :	-
order no. :	-
used for :	M+B Standardvessel
weight :	ca.1320 kg
sheet :	1
of sheet :	1
date of plot :	23.06.2015
file :	ENG-010805

Maschinen- und Behälterbau GmbH

date	name
compl. 23.06.2015	CW
appr. 23.06.2015	Nota 2

follow protection mark acc. to DIN 34

Betzdorfer Str. 170
57567 Daaden
Tel. 02743/9330-12
Fax 02743/3685
Internet: www.mabe.de
E-Mail: cad@mabe.de

description :	
pressure vessel horizontal 7000 l 11 bar	
drawing no. :	revision : A
MB 020102-1.7000G/E	
drawing no. of design inspection :	date of revision : 23.06.2015
MB 020102-1	revision only on CAD